

YFM/1006-2——1A 60V Opto-MOS

概述 Features

- 交直流通用 AC&DC load
- 负载电流至1A Load current up to 1A
- 击穿电压60V Breakdown voltage 60V
- 介质耐压3000V Dielectric strength 3000V
- 符合RoHS RoHS compliant

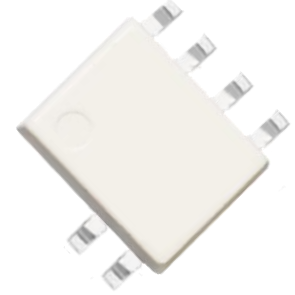

应用 Applications

- 高速检测设备 High-speed inspection machines
- 程控交换设备 Telephone equipment
- 计算机 Compute

打印标志 Marking information

Part number	Package	Marking
YFM/1006-2	SOP8	1006-2

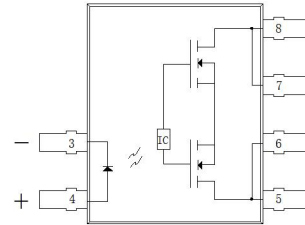

极限值/Absolute maximum ratings

(Ta=25°C)

特性参数/Parameter		符号/Symbol	测试条件/Test condition	最小值/Min.	典型值/Typ.	最大值/Max.	单位/Unit
输入端/Input	LED 反向电压/LED reverse voltage	V_R		6			V
	LED 正向电流/LED forward current	I_F				50	mA
	功耗/Power dissipation	P_{in}				50	mW
输出端/Output	击穿电压/Breakdown voltage	BV_{DSS}		60			V
	功耗/Power dissipation	P_{out}				500	mW
	额定电流/On-state current	I_L				1	A
	峰值电流/Peak current	I_{peak}	100ms (1 shot), VL=DC		1.8		A
介质耐压/Dielectric strength *		V_{iso}	$I_{iso} \leq 0.3mA$	3000			V_{rms}
工作温度/Operating temperature		T_{opr}		-30		85	°C
储存温度/Storage temperature		T_{stg}		-40		125	°C

“*”：RH=40 to 60%, T=20~30°C, AC for 1minute.

电参数 Electrical parameters

(Ta=25°C)

特性参数/Parameter		符号 /Symbol	测试条件 /Test condition	最小 值 /Min.	典型 值 /Typ.	最大值 /Max.	单位 /Unit
输入端/Input	LED 正向电压 /LED forward voltage	V_F	$I_F=10mA$		1.2	1.3	V
	LED 反向电流/LED reverse current	I_r	$V_r=5V$			10	μA
输出端/Output	断态泄漏电流/Output off-state leakage current	I_{Leak}	$V_o=60V$			10	μA
耦合特性 /Transfer characteristics	LED 触发电流/LED trigger current	I_{FT}				8	mA
	推荐的工作电流 /Recommend operating current	I_{in}		10		18	mA
	导通电阻/Output on-state resistance	R_{on}	$I_{in}=10mA, I_p=1A$			0.1	Ω
	导通时间/Turn on time	T_{on}	$I_{in}=10mA, I_p=1A$			4	ms
	关断时间/Turn off time	T_{off}	$I_{in}=10mA, I_p=1A$			4	ms
	电容/I/O capacitance	C					10

外形尺寸 Outline dimension

1、SOP8

单位：mm

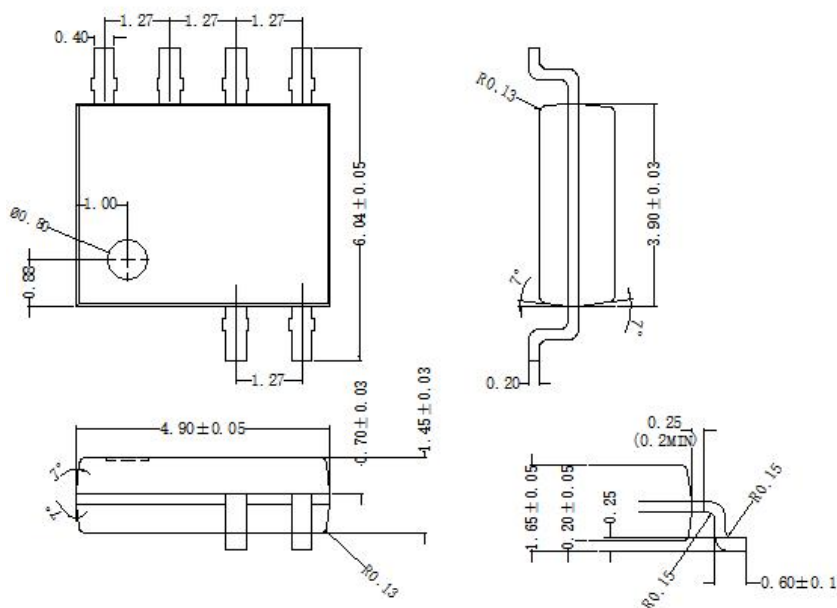

订货信息 Ordering information

订货信息/Ordering information					
	Y	FM	100	6	-2
公司商标代号 Company symbol					
SOP8 直流输出型 DC SSR					
负载电流 Load current: 100-1A					
击穿电压 BV_{DS} : 6-60V					
双 MOS					

包装信息 Package specification

每卷 4000pcs
每盒 8000pcs
每箱 64000pcs

SOP8 Embossed Carrier Tape

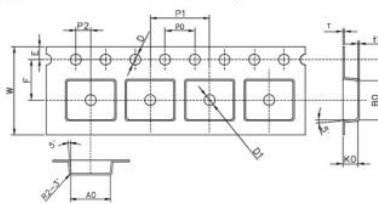

SOP8 Tape Leader and Trailer

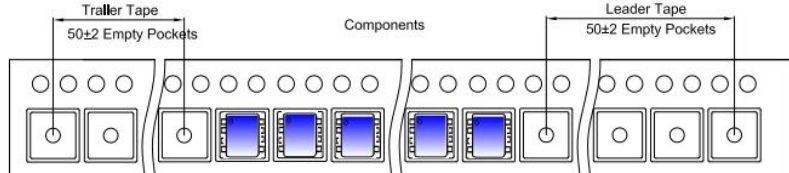

Dimensions are in millimeter										
Pkg type	A0	B0	K0	D	E	F	P0	P1	P2	W
SOP8	6.60	5.30	2.10	Ø1.55	1.75	5.50	4.00	8.00	2.00	12.00

SOP8 Reel

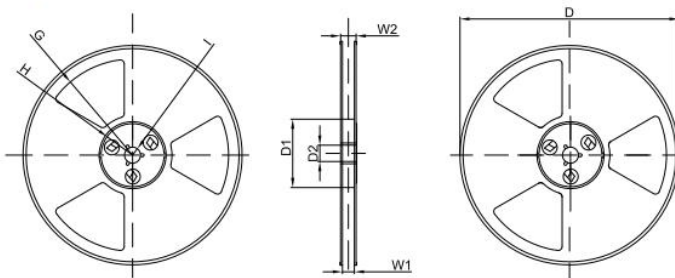



Dimensions are in millimeter							
Reel Option	D	D1	D2	G	H	I	W1
13" Dia	Ø330.00	100.00	13.00	R130.50	R44.50	R6.50	13.00

REEL	Reel Size	Box	Box Size(mm)	Carton	Carton Size(mm)
4000 pcs	13 inch	8,000 pcs	362×332×50	64,000 pcs	460×342×390

Packaging Description:

SOP8 parts are shipped in tape. The carrier tape is made from a dissipative (carbon filled) polycarbonate resin. The cover tape is a multilayer film (Heat Activated Adhesive In nature) primarily composed of polyester film, adhesive layer, sealant, and anti-static sprayed agent. These reeled parts in standard option are shipped with 4,000 units per 13" or 33.0 cm diameter reel. The reels are clear in color and is made of polystyrene plastic (anti-static coated).

图片	名称	代码	尺寸(mm)		描述
			长	宽*高	
	P8 内盒	H6	36.2	33.2*5cm	纸盒为本色； 表面有防静电标识及可回收标识； 标识为黑色。
	P8 专用外箱	J1	46	34.2*39cm	纸箱为本色； 封口上方有易碎标识(黑色)； 纸箱一侧有C/NO. 及信息方框 (内容: CUSTOMER、QUANTITY、 MFG. P/N、LOT NO.、DATE CODE、 QA) 黑色； 纸箱一侧有向上标识及信息 (内容 TYPE:、Q' TY: Kpcs、 N. W: KGS、G. W: KGS)。

安规要求 Safety and insulation ratings

爬电距离	Creepage distance	3.5mm, CTI \geq 275;
瞬时过电压	Highest allowable overvoltage	5000V;
再现峰值电压	V_{IORM}	769V;
局部放电	Partial discharge test voltage : method b, $V_{Pd} = V_{IORM} \times 1.6$	1230V.

特性曲线 Characteristic data

1. 负载电流与环境温度关系曲线 Load current VS. ambient temperature

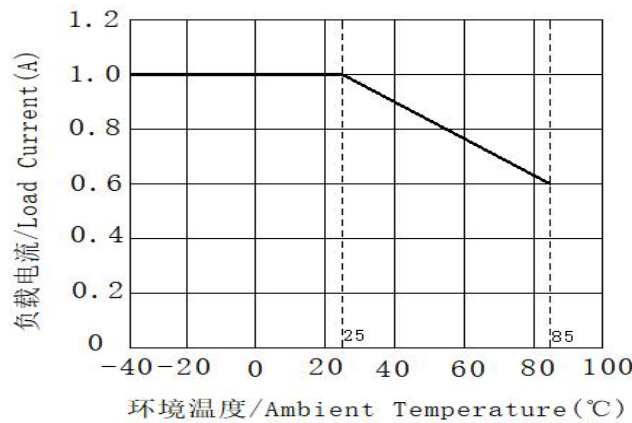

接通和关断时间关系 Turn on and turn off time

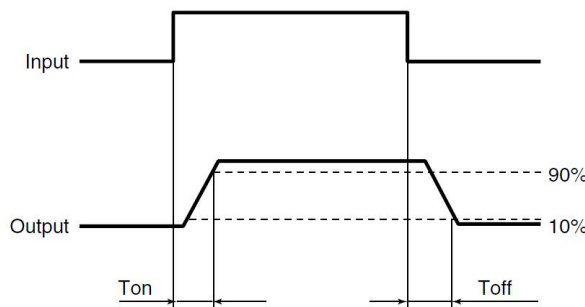

接线图 Wiring diagram

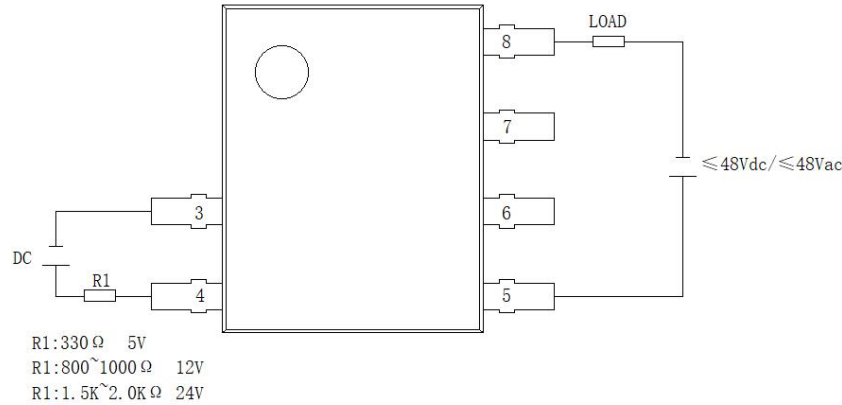

推荐使用的条件 Recommended driving condition

请确保输入电流大于 10mA，推荐输入电流为 15mA。请参考下图：

Please make sure the input current more 10mA, Recommending input current 15mA.

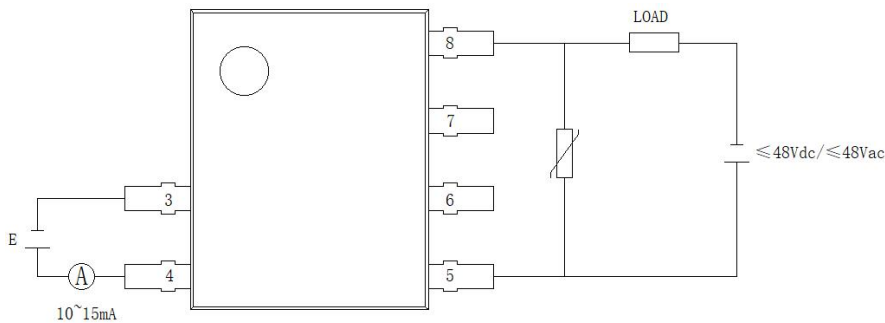

注意事项 Notes

a) 工作环境温度超过 25℃时请降额使用。参见特性曲线 1。

When ambient temperature is above 25℃, the load current must be reduced. (see characteristic data 1)

b) 继电器接线时，务必保证输入端极性的正确，以免损坏继电器。

Ensuring the polarity is correct when connecting the input lines, otherwise the wrong connection will damage the relay.

关于防静电对策 Cautions for static electricity

a. 操作 MOS 输出继电器的作业人员，请穿戴防静电工作服，通过 500k Ω ~1M Ω 左右的保护电阻，实施人体接地。

a. Employees handling relays should wear anti-static clothes and should be grounded through protective resistance of 500k Ω to 1M Ω .

b. 请在作业台上装有带导电性的金属板或具有防静电的专用板，并对测量仪器和治具等实施接地。

b. A conductive metal sheet should be placed over the work table. Measuring instruments and jigs should be grounded.

-
- c. 使用电烙铁时，对电烙铁前端进行接地。（建议使用低电压用的电烙铁。）
c. When using soldering irons, either use irons with low leakage current, or ground the tip of the soldering iron. (Use of low-voltage soldering irons is also recommended.)
- d. 组装时使用的设备等也应正确的接地。
d. Devices and equipment used in assembly should also be grounded.
- e. 对印刷电路板和机器进行包装时，请避免使用发泡苯乙烯、聚乙烯等带电性的高分子材料。
e. When packing printed circuit boards and equipment, avoid using high-polymer materials such as foam styrene, plastic, and other materials which carry an electrostatic charge.
- f. 对 MOS 输出继电器进行储存和搬运时，请在不易产生静电的环境(例如湿度 45~60%)中通过导电性包装材料进行保护。
f. When storing or transporting relays, the environment should not be conducive to generating static electricity (for instance, the humidity should be between 45 and 60%), and relays should be protected using conductive packing materials.